

Class 1500 - Standard Connection Specifications

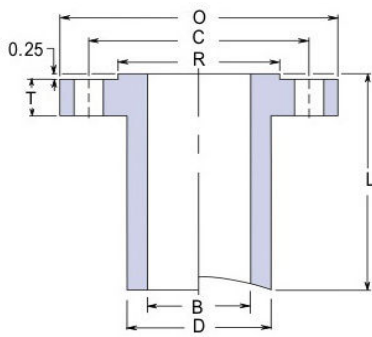

LONG WELD NECK "LWN"

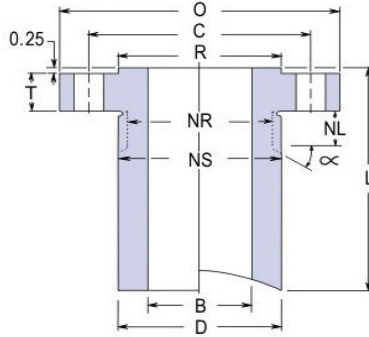

HEAVY BARREL "HB"

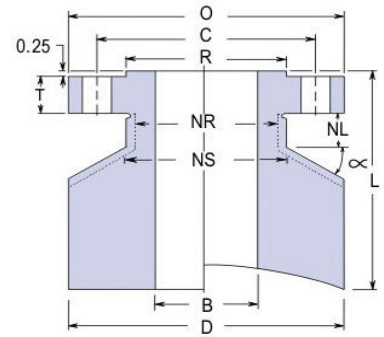

EQUAL BARREL "E"

Size		Flange			Barrel OD			Bolting			Nut			Stud Bolt			Weights						Length	
Nom	Bore LWN & E	Bore HB	OD	Thk	RF of OD	LWN	HB	E	# of Holes	Hole Size	Bolt Circle	Stop Dia	Relief Dia	Relief Length	Size	RF Length	RTJ Length	LWN		HB		E		Base
	B	B	O	T	R	D	D	D			C	NS	NR	NL				Base	Per 1"	Base	Per 1"	Base	Per 1"	L
1/2	0.50	0.55	4.75	0.88	1.38	1.56	2.00	4.75	4	0.88	3.25	2.00	1.56	1.00	3/4	4 1/4	4 1/4	8	0.5	10	0.8	37	5	9
3/4	0.75	0.74	5.12	1.00	1.69	1.81	2.25	5.12	4	0.88	3.50	2.25	1.81	1.00	3/4	4 1/2	4 1/2	10	0.6	13	1	42	5.7	9
1	1.00	0.96	5.88	1.12	2.00	2.12	2.56	5.88	4	1.00	4.00	2.56	2.12	1.12	7/8	5	5	13	0.8	17	1.3	54	7.5	9
1 1/4	1.25	1.28	6.25	1.12	2.50	2.50	2.94	6.25	4	1.00	4.38	2.94	2.50	1.12	7/8	5	5	17	1	20	1.6	61	8.3	9
1 1/2	1.50	1.50	7.00	1.25	2.88	2.75	3.25	7.00	4	1.12	4.88	3.25	2.75	1.25	1	5 1/2	5 1/2	21	1.2	26	1.9	77	10	9
2	2.00	1.94	8.50	1.50	3.62	4.12	5.06	8.50	8	1.00	6.50	5.06	4.12	1.12	7/8	5 3/4	5 3/4	42	2.9	56	4.9	115	15	9
2 1/2	2.50	2.32	9.62	1.62	4.12	4.88	5.88	9.62	8	1.12	7.50	5.88	4.88	1.25	1	6 1/4	6 1/4	56	3.9	75	6.5	144	19	9
3	3.00	2.90	10.50	1.88	5.00	5.25	6.19	10.50	8	1.25	8.00	6.19	5.25	1.38	1 1/8	7	7	67	4.1	84	6.7	161	23	9
4	4.00	3.83	12.25	2.12	6.19	6.38	7.50	12.25	8	1.38	9.50	7.50	6.38	1.50	1 1/4	7 3/4	7 3/4	110	5.5	147	9.3	302	30	12
5	5.00	4.81	14.75	2.88	7.31	7.75	9.12	14.75	8	1.62	11.50	9.12	7.75	1.75	1 1/2	9 3/4	9 3/4	181	7.8	233	13	414	43	12
6	6.00	5.76	15.50	3.25	8.50	9.00	10.31	15.50	12	1.50	12.50	10.31	9.00	1.62	1 3/8	10 1/4	10 1/2	215	10	272	16	445	46	12
8	8.00	7.62	19.00	3.62	10.62	11.50	12.94	19.00	12	1.75	15.50	12.94	11.50	1.88	1 5/8	11 1/2	12 3/4	337	15	417	24	629	67	12
10	10.00	9.56	23.00	4.25	12.75	14.50	16.06	23.00	12	2.00	19.00	16.06	14.50	2.12	1 7/8	13 1/4	13 1/2	546	25	651	37	888	97	12
12	12.00	11.38	26.50	4.88	15.00	17.75	19.38	26.50	16	2.12	22.50	19.38	17.75	2.25	2	14 3/4	15 1/4	946	38	1148	55	1683	127	16
14	14.00	14.00	29.50	5.25	16.25	19.50	21.50	29.50	16	2.38	25.00	21.50	19.50	2.50	2 1/4	16	16 3/4	1116	41	1308	59	1929	150	16
16	16.00	16.00	32.50	5.75	18.50	21.75	23.88	32.50	16	2.62	27.75	23.88	21.75	2.75	2 1/2	17 1/2	18 1/2	1371	48	1588	70	2238	178	16
18	18.00	18.00	36.00	6.38	21.00	23.50	26.25	36.00	16	2.88	30.50	26.25	23.50	3.00	2 3/4	19 1/2	20 3/4	1674	51	1959	81	2629	216	16
20	20.00	20.00	38.75	7.00	23.00	25.25	28.12	38.75	16	3.12	32.75	28.12	25.25	3.25	3	21 1/4	22 1/4	1943	53	2241	87	2868	245	16
24	24.00	24.00	46.00	8.00	27.25	30.00	33.62	46.00	16	3.62	39.00	33.62	30.00	3.75	3 1/2	24 1/4	25 1/2	2936	72	3334	123	3819	343	16

Dimensions are in inches. Weights are in pounds.